

SECTION 08460

HUNTER HA-8P & HA-8 AUTOSWING – **LOW ENERGY** - AUTOMATIC DOOR OPERATOR

1. GENERAL

1.01 Summary

- A. Work included:
 - 1. Electro-mechanical swing door operating equipment
 - 2. Controls and safety devices
 - 3. Accessories

- B. Related Work: [Insert applicable section including]
 - 1. Section 07900 – Caulking
 - 2. Section 08400 – Entrances and Storefronts
 - 3. Section 08710 – Finished Hardware
 - 4. Section 08800 – Glazing
 - 5. Section 12670 – Entrance Mats
 - 6. Section 16120 – Electrical Supply and Termination

1.02 Submittals

- A. Product Data: Provide manufacturer's product and complete installation data for all materials in this specification.

- B. Shop Drawings: Show profiles, joining methods, location of components, anchorage details, adjacent construction interfacing and dimensions as well as all necessary wiring and electrical requirements.

- C. Samples: Sized to adequately represent material

- D. Contract Closeout: Submit the Manufacturer's warranty and performance certification (if applicable)

- E. Installation Guide: Provide written installation and operating manuals and/or installation recommendations.

1.03 Quality Assurance

- A. Installation and maintenance shall be performed by an authorized dealer and in strict compliance with the manufacturer's recommendations.

- B. Conform to UL Std. 325 & ANSI-BHNA Std. A156.19 certified to Can. CSA Std. C22.2#247.

1.04 Product Handling

- A. All materials shall arrive in the manufacturers original sealed, labelled containers.

- B. Store materials in a dry, protected, well-vented area. Report damaged material immediately to the delivering carrier and note such damage on the carrier's freight bill of lading.
- C. Remove and dispose of all protective materials after installation.

1.05 Job Condition

- A. Verify that other trades are complete before installing the automatic swinging door system.
- B. Mounting surfaces shall be plumb, straight and secure; substrates shall be proper dimension and material.
- C. Refer to the construction documents, shop drawings and manufacturer's installation instructions.
- D. Coordinate installation with the glass, glazing and electrical work.
- E. Observe all appropriate OSHA safety guidelines for this work.

1.06 Warranty/Guarantee

- A. Manufacturer's Standard Warranty: Warranted materials shall be free of defect in material and workmanship for TWO years after installation

2. PRODUCTS

2.01 Manufacturer

- A. Hunter Automatics, Inc.
125 Kenyon Drive, Ste #3
Lakewood, NJ
08701
Phone: 1-866-901-4284
Fax: 1-877-901-4284
Website www.hunteraccesstechnologies.com E-mail info@hunteraccesstechnologies.com

2.02 Automatic Swinging Door Operator

- A. Automatic Door Operator: Shall be HUNTER AUTOSWING HA-8. The system shall be an electro-mechanical system installed in a header to resist dust, dirt and corrosion. Bearings shall be fully lubricated and sealed to minimize wear and friction. Entire operator shall be removable from the header as a unit. All equipment shall operate between temperature extremes of -30 degrees F and +130 degrees F.
- B. Power Opening: Operator shall open door with a 1/5 HP motor through reduction gears splined spindle, door arm and linkage assembly. Drive train shall have positive constant engagement. Operator shall stop the door in the open position by electrically reducing the motor voltage and stalling against stop.
- C. Spring Close: Operator shall close door by spring energy. Employing the motor as a dynamic brake shall control closing speed. Closing spring shall be pre-loaded for positive closing action. "Low energy" operator door closing time shall not be less than 4.5 seconds.
- D. Manual Operation: Operator shall function as a manual door closer in the direction of swing with or without electrical power. To facilitate easy manual operation of door and to prolong gear and motor life the operator must have a one-way clutch in the gear train.

- E. Entrapment Protection: Door forces and speeds generated during power opening and manual opening in both directions of swing and spring closing in both directions of swing shall conform to the requirements of A 156.19.

- F. Electrical Control: Electronic controllers with quick connect plugs shall incorporate the following features:
 - 1. Mode of Operation: To be “low energy” as defined by A 156.19.
 - 2. Respond to push plates, transmitters and receivers.
 - 3. Immediate reverse-on-obstruction during opening capability.
 - 4. Open, back check and closing speed adjustment.
 - 5. Adjustable time delays.
 - 6. On/Off/Hold-Open switch.

- G. Header: Shall be 4-1/2” wide by 6-1/2” high, 6063-T5 aluminum extrusions with structurally integrated end caps. Structural sections shall have a minimum wall thickness of .125”. Provide full length removable cover for access to operator and electronic control box.

- H. Aluminum Extrusion Finish: Standard anodized finish shall be Clear, Bronze or Light Bronze. Special anodized, painted and clad finishes are available upon request. Specify type and color.

- I. Linkage Assembly: Shall provide positive control of door through entire swing; Surface applied permit use on butt-hung or offset pivots. Concealed permit use on center pivot, butt-hung, and offset pivots.

- J. Controls: Push Plates, Transmitters, Safety Sensors, Card Readers, etc.

3 EXECUTION:

3.01 Inspection:

- A. The door installer shall verify that the installation area is dry, clean and free of foreign matter. Check as-built conditions and verify the manufacturer’s details for accuracy to fit the wall assembly prior to fabrication. Report in writing to the Contractor any detrimental conditions to the proper functioning of the swinging door operator. Correct prior to any installation in accordance to the manufacturer’s recommendations.

3.02 Installation of Automatic Swinging Door System

- A. Installation shall be by an installer approved and trained by the manufacturer in strict accordance with the manufacturer’s instructions and fire marshal’s listing requirements.



- B. Comply with the automatic swinging door system manufacturer's recommendations and/or installation guide when installing the automatic swinging entrance system. Set all units plumb, level and true.
- C. Provide all fasteners required for installation of the automatic swinging door system.
- D. Adjustment and Cleaning: After repeated operation of the completed installation, re-adjust door operators and controls for optimum operating condition and safety. Clean all metal surfaces promptly after installation.
- E. Explain and review the Daily Safety Check Procedure.

END SECTION 08460

VISIBLE APPLICATION

PULL APPLICATION

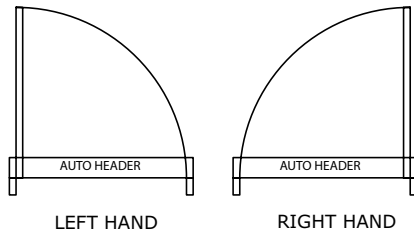

PUSH APPLICATION

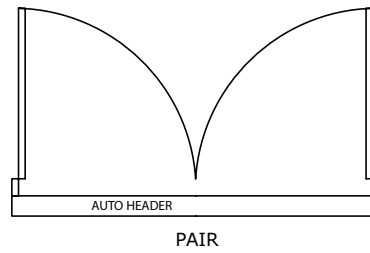
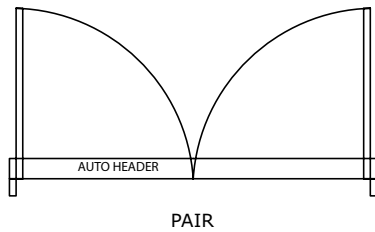
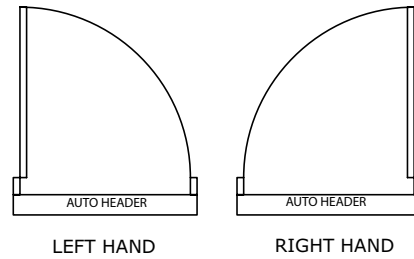

CONCEALED APPLICATION

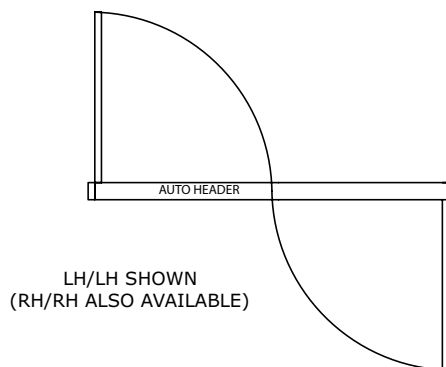
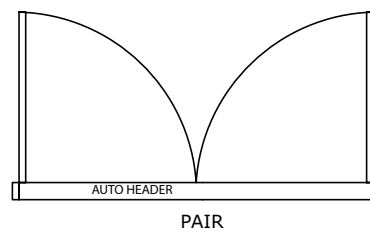
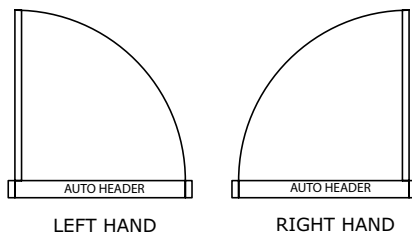

SHEET	DOOR TYPE	DESCRIPTION
P1	HA-8-1-3	RIGHT HAND PUSH
P2	HA-8-1-4	LEFT HAND PUSH
P3	HA-8-1-5	PAIR DOORS PUSH
P4	HA-8-2-3	RIGHT HAND PULL
P5	HA-8-2-4	LEFT HAND PULL
P6	HA-8-2-5	PAIR DOORS PULL
P7	HA-8-CH-3	CONCEALED RIGHT HAND SINGLE DOOR CENTER PIVOT
P8	HA-8-CH-4	CONCEALED LEFT HAND SINGLE DOOR CENTER PIVOT
P9	HA-8-CH-5	CONCEALED PAIR DOORS CENTER PIVOT
P10	HA-8-CS-3	CONCEALED RIGHT HAND WITH BUTT HUNG OR OFFSET PIVOT
P11	HA-8-CS-4	CONCEALED LEFT HAND WITH BUTT HUNG OR OFFSET PIVOT
P12	HA-8-CS-5	CONCEALED PAIR DOORS WITH BUTT HUNG OR OFFSET PIVOT